

A

B

C

D

E

F

G

H

1. Material/Plated
  - 1.1 Housing: High temperature thermoplastic, Black UL 94V-0.
  - 1.2 Terminal: Copper Alloy, Gold Flash Plated At Contact Area, Gold Plated At Soldered Area, Nickel Underplated Overall
  - 1.3 Shell-1: Kirsite, Nickel plated
  - 1.4 Shell-2: Stainless steel
  - 1.5 Ring: Silicon
  - 1.6 Epoxy: Epoxy, Black
2. Electrical Performance
  - 2.1 Rated Voltage: 30V AC
  - 2.2 Rated Current: 1, 5Pin: 3.0A Max. 2, 3, 4Pin: 1.0A Max.
  - 2.3 Contact Resistance: 30mΩ Max.
  - 2.4 Insulation Resistance: 100MΩ Min.
  - 2.5 Dielectric Strength: 100V AC
3. Mechanical Performance
  - 3.1 Insertion Force: 35N Max.
  - 3.2 Withdrawal Force: 8-35N
  - 3.3 Durability: 10000 Cycles
4. Operating Temperature: -25° C To +85° C
5. Waterproof: IPX8

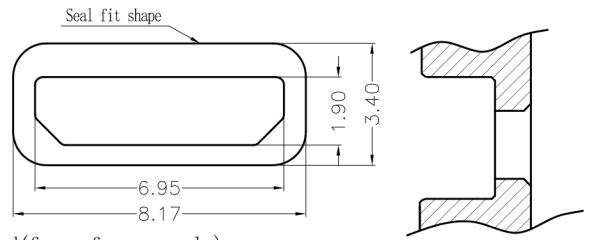
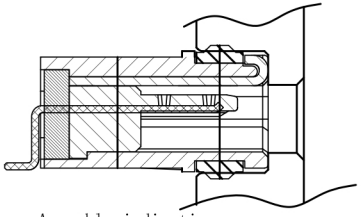
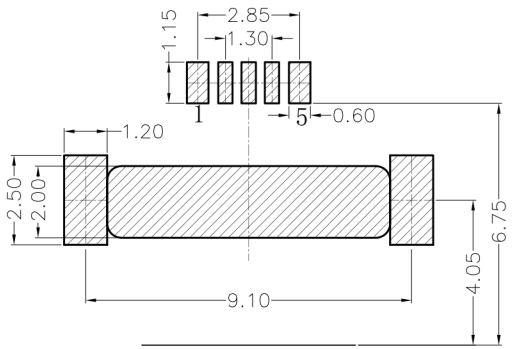
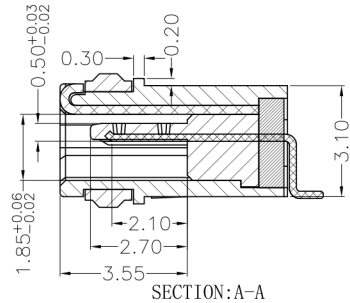
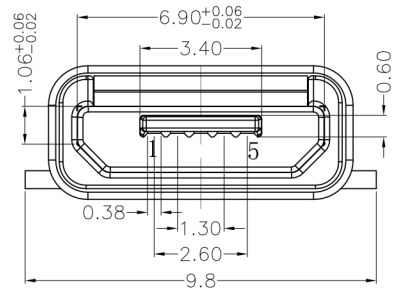
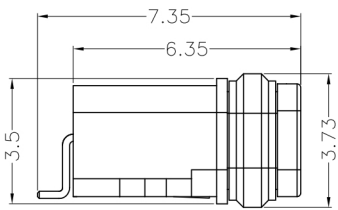
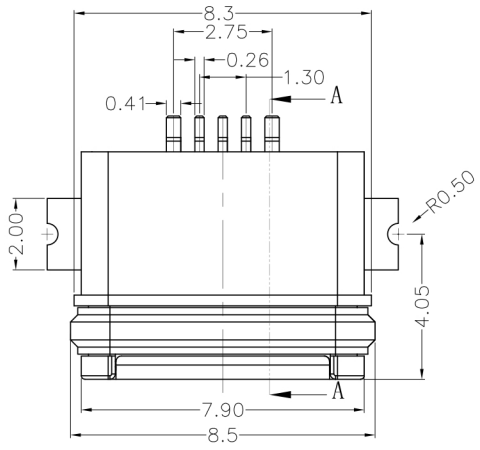
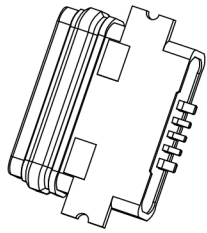

Sealing method(for reference only)

REV.	DESCRIPTION	ECN NO.	NAME	DATE
A	NEW RELEASE		Tom	2018-06-13
REVISIONS				

DRAWN	Tom	2018-06-13
CHECKED	Ango	2018-06-13
APPROVE	Kevin	2018-06-13
SCALE:	N/A	
SHEET:	1 OF 1	

DIMENSION TOLERANCE	
X	
X.X	±0.35
X.XX	±0.25
X.XXX	±0.15
GENERAL ANGLE: ±3°	
UNIT: mm	
LEVEL	C31

<b>东莞市神久电子科技有限公司</b> Dongguan Shenjiu Electronic Technology Co., Ltd	
TITLE	Micro USB B 5P Waterproof SMT H3.1
PART NO.	UMX-024S1AP
DWG. NO.	