

1. Material/Plated
 - 1.1 Housing: High temperature thermoplastic, Black UL 94V-0.
 - 1.2 Cover: High temperature thermoplastic, Black UL 94V-0.
 - 1.3 Terminal: Copper Alloy, Gold Flash Plated At Contact Area, Gold Plated At Soldered Area, Nickel Underplated Overall
 - 1.4 Shell: Stainless steel, Nickel plated Overall
 - 1.5 Out Shell: Stainless steel, Nickel plated Overall
 - 1.6 Ring: Silicon
 - 1.7 Epoxy: Epoxy, Black
2. Electrical Performance
 - 2.1 Rated Voltage: 30V AC
 - 2.2 Rated Current: 1,5Pin: 3.0A Max. 2,3,4Pin: 1.0A Max.
 - 2.3 Contact Resistance: 30mΩ Max.
 - 2.4 Insulation Resistance: 100MΩ Min.
 - 2.5 Dielectric Strength: 100V AC
3. Mechanical Performance
 - 3.1 Insertion Force: 35N Max.
 - 3.2 Withdrawal Force: 8-35N
 - 3.3 Durability: 10000 Cycles
4. Operating Temperature: -25° C To +85° C
5. Waterproof: IPX8

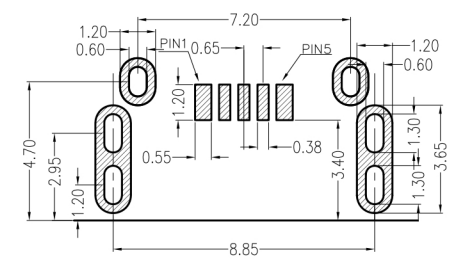
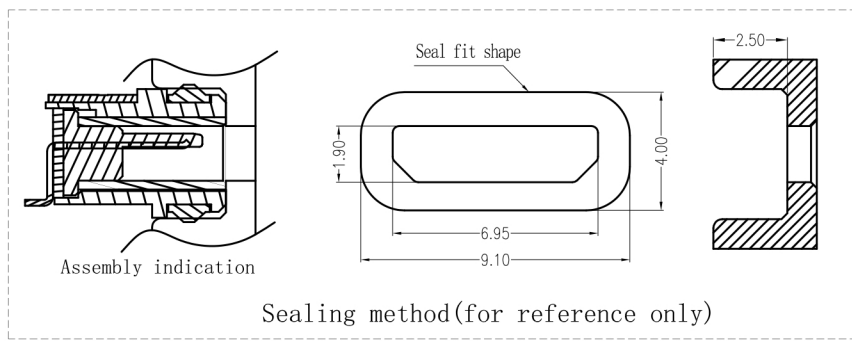
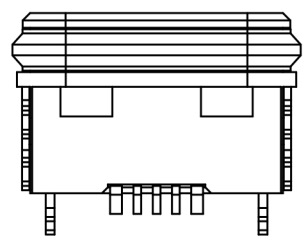
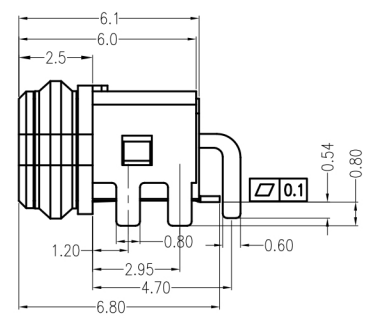
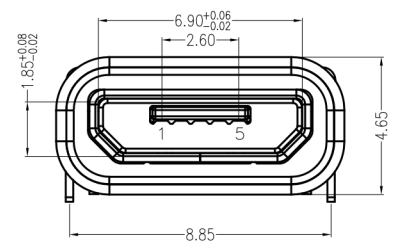

					DRAWN	Tom	2018-06-13	DIMENSION TOLERANCE X ±0.35 X.XX ±0.25 X.XXX ±0.15 GENERAL ANGLE: ±3° UNIT: mm	
					CHECKED	Ango	2018-06-13		
					APPROVE	Kevin	2018-06-13		
REVISIONS					SCALE: N/A	SHEET: 1 OF 1			
A	NEW RELEASE		Tom	2018-06-13				LEVEL	C31
REV.	DESCRIPTION	ECN NO.	NAME	DATE					

东莞市神久电子科技有限公司 Dongguan Shenjiu Electronic Technology Co., Ltd	
TITLE	Micro USB B 5P Waterproof DIP
PART NO.	UMX-023H1AP
DWG. NO.	